

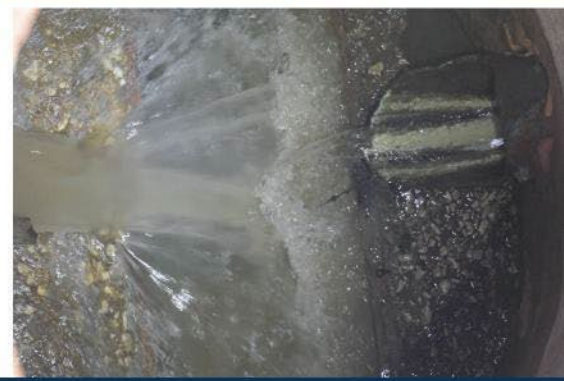

YOUR TEAM FOR SECURE + RELIABLE  
**Water System Solutions**



Proposal

# **The Village of Romeoville, Illinois**

Water Loss Control Program





May 1, 2026

Mr. Chris Drey  
Public Works Director  
Village of Romeoville  
615 Anderson Drive  
Romeoville, IL 60446

**RE: WATER LOSS CONTROL PROGRAM**

Dear Mr. Drey,

M.E. Simpson Co., Inc. is pleased to present the Village of Romeoville our proposal for its Water Loss Control Program. We are honored to be considered for this work and are confident our team will help make the project a success.

M.E. Simpson Co., Inc. is a Professional Services Firm dedicated to developing and providing programs and services designed to maximize peak performance for our clients' water distribution systems. Many of these programs are universally recognized as a part of "Best Management Practices" (BMPs) for utilities. We pride ourselves on delivering solid solutions using the highest quality technical and professional services by way of state-of-the-art technology and a skilled and well-trained staff of professionals. Our highly educated engineers and technical team are committed to the success of this project. They will be ready at a moment's notice to relieve your staff's burden and ensure a seamless continuation of your services.

Our services were developed and refined to provide utilities with programs that can be customized to meet their needs. From complete "Turn-Key" services to assisting with the development of "in-house" programs for utilities, M.E. Simpson Co., Inc. serves our clients with this ultimate goal: to deliver to the public the implicit faith that **"the water is always safe to drink"**.

Thank you for your consideration and this opportunity to acquaint you with our Water Loss Control Services and offer this response. We are committed to exceeding your expectations.

Sincerely,

Randy Lusk  
Vice President

**Randy Lusk**  
Vice President

3406 Enterprise Avenue  
Valparaiso, IN 46383

800.255.1521 P  
888.531.2444 F

randyl@mesimpson.com

## GENERAL FIRM QUALIFICATIONS

Working together with our clients to create secure water distribution systems is what drives our practice.

### Company Overview

For 40 years, M.E. Simpson Co., Inc. has helped utilities across the U.S. locate and resolve water loss control issues so customers could confidently provide safe, quality water to the community. We use state-of-the-art programs to assist utilities with their meters or water distribution systems condition and performance shortfalls. Simpson's trained professionals work hand-in-hand with utility team members to set up monitoring systems that help them avert future problems.

## KEY QUALIFICATIONS

Our team brings the necessary experience for a project of this magnitude, as well as the personal attributes needed to serve the Village of Romeoville with distinction.

We offer our clients the highest quality technical and professional services, using state-of-the-art technologies and highly skilled and trained professionals. The M.E. Simpson Co., Inc. team members selected to serve the Village of Romeoville bring significant experience and a proven track record of delivering timely, cost-effective and sound water distribution and wastewater collection solutions. They share a passionate commitment to client service and attention to detail required for a successful project.

The following Organizational Chart illustrates the Project Team for the Village's Water Loss Control Program. One of the two Project Leaders listed will lead the Project Team in the field. **Two-Man Project Teams will be used at all times during the course of the project for reasons of safety and quality assurance.**

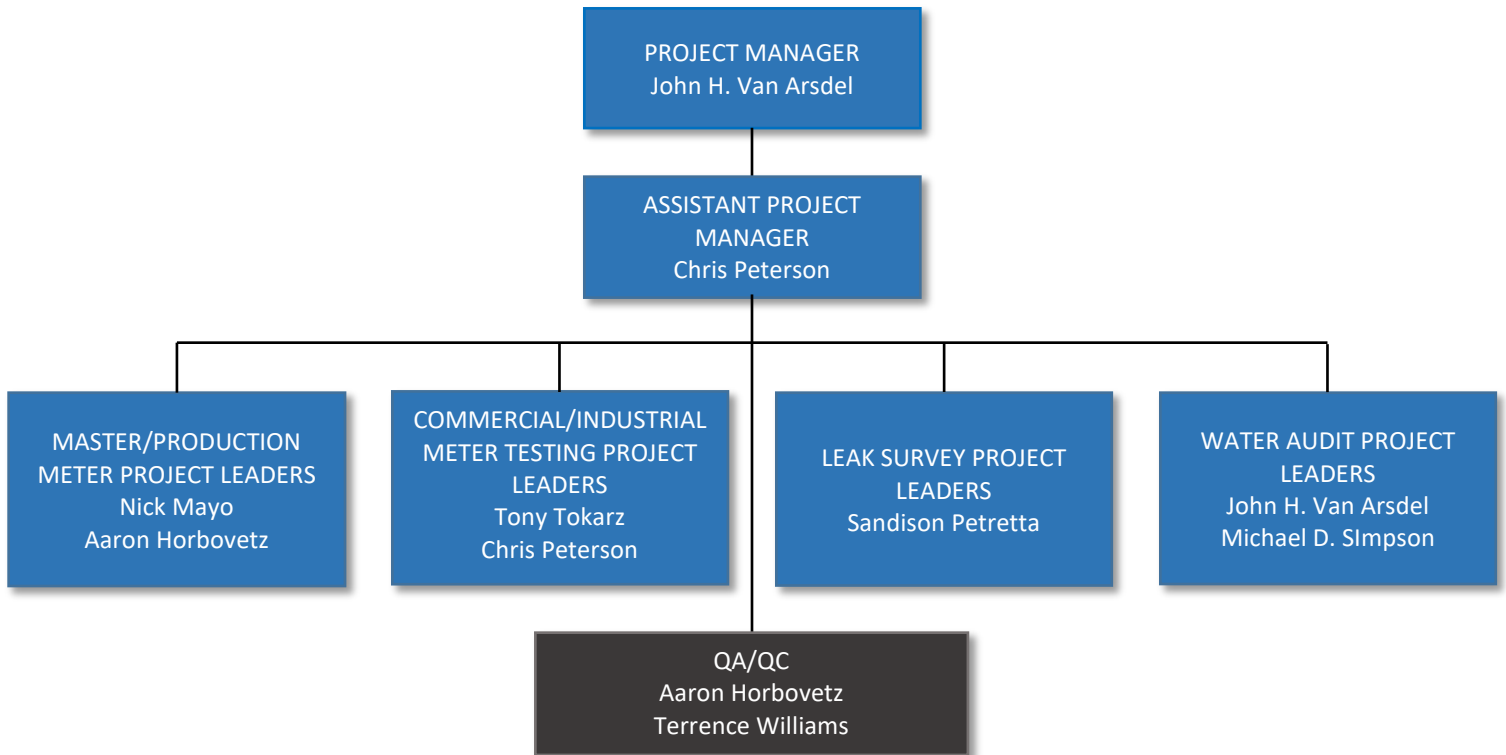

## Project Manager

### John H. Van Arsdel

John H. Van Arsdel has been with M.E. Simpson Co., Inc. since May 1989. He graduated from Valparaiso University with a B.A. in Geography with an emphasis in Locational Evaluation and Research Design. John has completed water operators classes and seminars on Water Filtration and Distribution, Vulnerability Assessment Class for the Sandia Labs RAM-W method and the RAM-W “modified” for small to medium systems (currently licensed to use the Sandia Labs RAM-W Method, and licensed to teach the RAM-W “modified” for small to medium water systems), along with classes related to the operation and maintenance of water meters, and system hydraulics specifically related to the Polcon® Flow Testing equipment.

John has over 27 years of experience directing projects for water utilities concerning water audits, loss prevention, leak detection programs, meter evaluation and maintenance, flow testing using the Polcon® Flow Testing method (large flow meter assessments, C-factors, pump curves, zone flow measurements), mainline valve assessments (location, exercising and mapping programs), and fire hydrant and main capacity flow testing programs. John has been responsible for the analysis, evaluation, and CAD updating of Water Distribution, Sanitary, and Storm Sewer Atlases using GPS locating. He developed the Company’s Unidirectional Main Flushing Program and Utility Atlas Updating Program.

John has presented classes for continuing education credits for water operators for over eighteen years to several local and state Water Works Organizations on Water Loss Reduction including Water Audits, Leak Detection, Meter Testing and Flow Testing. John has presented papers at the AWWA ACE in 2007, 2008, 2009, and 2012; at the 2010, 2011 and 2012 AWWA DSS, he presented papers on water loss reduction. Since 2003, he has conducted classes on Vulnerability Assessments and Emergency Response Planning for water utilities as well as conducting several VA and ERP projects. He served from 2010 to 2014 as Chair of the AWWA Water Loss Control Committee. As Vice President of M.E. Simpson Co., Inc., John serves as the main point of contact for client development, business sales and customer relations for the Eastern U.S.

**Professional Certifications:**

- ◆ 10-Hour and 30-Hour OSHA Certified for General Industry
- ◆ American Red Cross First Aid and CPR with AED Certified
- ◆ American Traffic Safety Services Association Flagging Certified

## Assistant Project Manager

### Project Leaders

#### Chris Peterson

##### Large Water Meter Evaluation, Testing & Repair Commercial/Industrial Water Meters

Chris Peterson has been with M.E. Simpson Co., Inc. since August 2006. Chris has attended numerous classes and lectures on the operation and maintenance of water meters. He has experience in the maintenance and installation of water meters, valve location, exercising and mapping, and the use of state of the art leak detection equipment.

Chris experienced in the operation and maintenance of water meters, fire hydrant and main capacity flow testing, and the operation of our Polcon® Flow Testing equipment.

**Professional Certifications:**

- ◆ 10-Hour OSHA Certified for General Industry
- ◆ American Red Cross First Aid and CPR with AED Certified
- ◆ American Traffic Safety Services Association Flagging Certified
- ◆ Extensive traffic control training
- ◆ Extensive confined-space training

#### Tony Tokarz

##### Large Water Meter Evaluation, Testing & Repair Commercial/Industrial Water Meters

Tony Tokarz has been with M.E. Simpson Co., Inc. since November 2006. He is a graduate of Portage High School. Tony was previously in the Army. Tony is experienced in the following: the operation and maintenance of water meters; valve location, exercising and mapping; use of state of the art leak detection equipment, and the operation of our Polcon® Flow Testing equipment.

**Professional Certifications:**

- ◆ 10-Hour OSHA Certified for General Industry
- ◆ American Red Cross First Aid and CPR with AED Certified
- ◆ American Traffic Safety Services Association Flagging Certified
- ◆ Extensive traffic control training
- ◆ Extensive confined-space training
- ◆ Forklift Operator

## QA/QC

### **Aaron M. Horbovetz, PE, PMP**

Aaron Horbovetz has been with the Company since September of 1999. He earned his degree in Mechanical Engineering from Purdue University, completed his EIT work and recently passed the PE exam for the state of Indiana. Aaron is a regular presenter at AWWA conferences since 2012, both at section meetings and at the ACE conferences. He has attended numerous classes and lectures related to the operation, maintenance and installation of water meters, and completed classes in plumbing. Aaron has experience in the following: maintenance and installation of water meters; valve location, exercising and mapping, fire hydrant and main capacity flow testing, and the use of state-of-the-art leak detection equipment; and is also very experienced in the use of all of our Polcon® Flow Testing equipment.

**Professional Certifications:**

- ◆ Licensed Professional Engineer, Indiana
- ◆ Certified Project Management Professional (PMP)
  - Member of Project Management's Institute Calumet Chapter
- ◆ 10-Hour OSHA Certified for General Industry
- ◆ American Red Cross First Aid and CPR with AED Certified
- ◆ American Traffic Safety Services Association Flagging Certified
- ◆ Extensive traffic control training
- ◆ Extensive confined-space training

# PROJECT UNDERSTANDING & APPROACH/SCOPE OF WORK

## Water Loss Control Survey—Audit Approach

Our **Water Loss Control Survey/Audit** program is a multi-phase plan encompassing a select group of our services that will assist your Utility in improving water accountability and optimizing your distribution system's operational performance. Our program will be structured around your specific needs so that you can optimize your results and maintain flexibility in the performance of the various tasks. The Project Team will submit a questionnaire for particular details required for the review. The Utility will provide all relevant information to conduct the water audits. In the collection and review of the data, a hierarchical approach will be used.

- ◆ *Current* information found in the water utility reports and files will be used as the initial set of data. Some discrepancies among the data sets will be resolved by contacting water utility staff.
- ◆ *Older* legacy water utility data may be consulted and used. When appropriate, the information will be prorated to reflect changes in the system, including production and consumption for particular years or the audit period.
- ◆ In the absence of specific data for the water utility, information and assumptions from other audit workbooks and published literature may be used. Important references will include certain AWWA manuals and papers from the various IWA/AWWA water loss conferences (such as *Leakage 2005*, *Leakage 2007*, and *Water Loss 2009*), etc. For example, small and large meter accuracies have major impacts on the results of water audits. If the water utility does not have the data to support their estimated accuracy, then the Project Team may use data from the literature to estimate such *Apparent Losses*. As an option to the utility, a statistical sample of meters can be tested to get a more accurate estimate of incorrect registration.
- ◆ Cost data such as the annual operational costs and marginal costs will need to be supplied to complete the audit.
- ◆ Physical parameters of the water system will need to be gathered in order to make certain calculations.
- ◆ In some cases, audit data may not be available until field testing has been completed, then the compiled field test results will be used for the audit data inputs.
- ◆ Timeframe for the Water Audit Completion, 12-14 weeks.

## Task 1: Determine System Input

The first phase of our Water Loss Control Survey/Audit is to evaluate your water production through the master water meters to insure the input into the system has been accurately documented. All water audits have to start with verification of the distribution system input to insure reliable water production amounts.

### Record Review

All master meter production data for the selected audit period will be reviewed along with an examination of any past master meter test results. This may include any reports periodically submitted to the state's regulatory agencies or regional water authorities. Total pumping amounts for the audit period will need to be determined along with the marginal costs of water production.

### Master Meter Evaluation

Part of the first phase will include evaluations of your master water meters to insure all the meters are in compliance with AWWA standards for water meters. These evaluations can help verify your total water production volume for the audit period and help determine the actual water loss. All master meters would be evaluated in accordance with American Water Works Association standards (reference AWWA M6 and M33 Manuals).

### Evaluations

- ◆ The Project Team may need to assess all master meter sites. The settings would be analyzed to determine meter layout. This site assessment should be done prior to any data review so that factors possibly affecting meter accuracy can be determined.
- ◆ Schedule evaluations with the Utility during normal working hours. Exceptions to evaluation times will be made on a case-by-case basis, depending on accessibility to the meter.
- ◆ Past meter test flow data will be examined, if available.
- ◆ Production data for at least 12 months would need to be trended, and if available, the last 36 months as well.
- ◆ Test results from the Master Meter testing (described later) will be used for this data input.

## Task 2: Determine Authorized Consumption

All studies and reports on previous water loss for the utility will be reviewed with the goal of refining and updating previous techniques. The Project Team will also carry out a detailed review of current water loss practices to identify cost effective loss reduction strategies. A brief review of the accounting and billing system is also imperative for this phase of the program the following items must be thoroughly researched and quantified for the 12-month audit period:

- ◆ Billed Metered Water
- ◆ Billed Unmetered Water
- ◆ Unbilled Metered Water

- ◆ Unbilled Unmetered Water

## Billed Metered Water

The meter accounting and billing evaluation may help locate inconsistencies within the accounting, meter reading and billing cycles, identify problems resulting from inaccurate reading or recording of the individual accounts of metered water and to identify possible potential meter accuracy problems. The evaluation will allow the development of cost-effective recommendations for the correction of the problems located.

Select information for various meter accounts and the historical consumption for at least 12 months of time (typical audit period of one year) may be copied from the Water Utility's database. This information would be imported to the Project Team's program for review and evaluation. The type of information maintained in the Water Utility's database will determine the depth of our evaluation.

The following consumption evaluation will be performed on the data that is available.

- ◆ Perform analysis of pumped finished water versus billed water
- ◆ Review of your account billing cycles, procedures and practices.
- ◆ Review of your account meter reading cycles.
- ◆ Review of your account meter reading procedures and practices.
- ◆ Consumption patterns and trends are developed to locate decreasing or erratic historical use.
- ◆ Usage patterns of meters by sizes are reviewed.
- ◆ An evaluation of revenue is performed.

## Billed Unmetered Water

All account information regarding unmetered water that is billed such as possible bulk sales, estimated consumptions, fire service water used, etc. will be evaluated.

## Unbilled Metered Water

Water used by municipal buildings or departments that is metered but for some reason is not billed such as park departments, pools, schools, government buildings, etc., will be evaluated. This water may very well be tracked as far as consumption is concerned but no revenue is generated from its use. Hence, this would be termed as a part of "Non-Revenue Water".

## Unbilled Unmetered Water

Water use in this area is usually hard to predict and sometimes tough to estimate. It could be seasonal hydrant flushing, fire system flushing, street cleaning, and fire suppression. Theft of water, however, is not part of this. It is covered under unauthorized consumption. Unbilled Unmetered Water is part of "Non- Revenue Water" and the utility is not gaining an income from it. The account review can sometimes uncover accounts not being billed properly.

Once the Authorized Consumption has been totaled, it can be subtracted from Water Supplied to yield the water loss totals. The water loss total can be split into Apparent Losses and Real Losses.

### Task 3: Determine Apparent Loss

Apparent losses will be calculated by gathering data from the utility on unauthorized use, calculating meter inaccuracies, and identification of potential data handling errors for the above task of record review. Unauthorized use is a tough area to determine and requires some estimates to be made. However, reviewing customer service requests and reporting of open hydrants, et al will help validate this information. The use of the Utility's GIS system (if available) will contribute greatly to helping accomplish this task.

#### Commercial-Industrial Meter Accuracy Levels

In order to validate corrected consumption for the audit, the large commercial/industrial meter accuracies need to be verified. Since the majority of water use occurs through these meters, this is a needed task. Statistically significant random sampling (95% confidence) can be used to select meters by age, size and types for review. The Project Team will evaluate through the billing and accounting processes, the 1-1/2" and larger commercial / industrial water meters for right sizing, performance and accountability. We will review accounting, billing and reading practices with the goal of increasing revenues and improving accountability. Meters that may have been tested for accuracy in the field will have the test results evaluated and the weighted results of the tests can be applied to the Apparent Losses. 12 months of totalized meter data will be needed for the audit period. 36 months of data is preferred.

#### Small Commercial/Residential Meter Accuracy Levels

In order to validate corrected consumption for the audit, the small commercial - residential meter accuracies need to be verified. While these meters may not individually be a big cause of water loss, cumulatively they can be, thus, this is a needed task. Statistically significant random sampling (95% confidence) can be used to select meters by age, size and types for review. The Project Team will evaluate selected information for 5/8" through 1" water meters for performance and accountability. We will review accounting, billing and reading practices with the goal of increasing revenues and improving accountability. Meters that may have been tested for accuracy in the field will have the test results evaluated and the weighted results of the tests will be applied to the Apparent Losses.

#### *Needed from the Utility*

- ◆ The Utility will furnish all records necessary to properly conduct the evaluation program.
- ◆ The Utility will provide customer records such as the 12 month (36 months preferred) consumption history, meter sizes, meter types or any additional information that would make the meter evaluation easier to perform. This information shall be regarded as CONFIDENTIAL and will not be shared with anyone outside of the Utility without consent of the Utility.

- The Utility will also make available, on a reasonable but periodic basis, certain personnel with a working knowledge of the water system who may be helpful in the identification of particular issues and for general information about the water system. This person will not need to assist the Project Team on a full time basis, but only on an “as needed” basis.

Systematic data handling issues will also be looked at from the previous evaluation of the billing and accounting processes. It may be prudent to trace particular accounts through the reading process to the billing process to locate potential points of data failure.

Once the above tasks have been completed, the total Apparent Losses will be calculated.

#### **Task 4: Determine Real Losses**

Once the Authorized Consumption has been determined and validated, the calculated Apparent losses derived, and then Real losses can be calculated. This will be done by subtracting the Apparent Losses from the Total Losses to yield Real Losses. The Real losses can be validated as well by conducting an evaluation and review of the current leak detection methods employed by the Utility. Real losses are defined as water lost to actual leakage.

#### **Task 5: AWWA Water Audit Spreadsheet**

The last phase is to prepare a Water Audit using the AWWA Water Audit Software Version 5. We input the information and data gathered in phases 1-4 into the AWWA spreadsheet-based water audit tool. This software is design to help quantify and track water losses associated with water distribution systems and the areas for improved efficiency and cost recovery.

Non-Revenue water will be calculated indicating the amounts of water not generating revenue. Non-Revenue water can be calculated by adding the total water loss to unbilled metered water plus the unbilled unmetered water.

#### **Performance Indicators**

Certain cost data will be gathered from the Utility to help calculate the Performance Indicators. These indicators are made up of the Financial Indicators, as well as the Operational Efficiency Indicators.

The financial indicators will indicate how much revenue is lost due to Apparent losses (metering, billing, accounting issues) and Real losses (leakage in the system). By categorizing these losses, the amount of potential recovery for each area is identified to help plan for particular remediation techniques. An important aspect of the Real loss calculation will be the Unavoidable Real Losses. These are losses that occur even in the best run water systems. The calculation of Unavoidable Losses is done by applying a theoretical formula comprised of total water main lengths, lengths of service connections, number of service connections and system pressure. By dividing the Current Annual Real Losses by the Unavoidable Real Losses, the ILI, or Infrastructure Leakage Index is calculated. This ratio performance indicator is used for comparison of one water system to another. This ILI level will help the Utility and Project Team decide on a strategy of where and how much money may need to be spent for remediation. ILI ratios

are based on the current conditions of the water system and reflect the characteristics of the system and relate water resources to financial considerations as related to operational considerations.

Other indicators such as the Apparent losses per connection per day, Real losses per mile of pipe per day, Real losses per service connection per day, and Real losses per meter (head) pressure per day, are especially useful for smaller water systems less than 3,000 connections, or less than 80 miles of pipe in the distribution system where the ILI will be calculated but not displayed. This lack of display is because the ILI has not yet been proven for smaller water systems due to not having enough statistical data available at the time the Water Audit Spreadsheet was developed by the Water Loss Committee of the AWWA.

### Validity Scores

While the Audit Spreadsheet is being filled out, validity scores will be assigned to segments of the data. This is done to provide a basis of understanding of how robust the data from the utility is. The data validity score is a useful tool in helping determine areas of remediation in record keeping for a water utility. It also acts as a tool for “self-evaluation” to insure data integrity. This step is one of the most important steps of the audit process. Without this data validation, the audit process is subject to serious flaws. This area will have a great deal of scrutiny applied and is by far the single most important QA/QC segment of the audit process.

## Task 6: Recommendations for Economically Viable Water Loss Intervention Programs

The AWWA Spreadsheet has “built in” generalized suggestions of system improvements based on the scoring system (“ILI” or Infrastructure Leakage Indicator and confidence level of data used) that can help direct long term programs. However, following the completion of the Water Audit Spreadsheet and the results of the previous tasks, the Project Team may also develop a detailed prioritized set of recommendations on cost effective ways to continue to identify and remediate Apparent and Real Losses.

Each suggested task for water loss reduction may encompass details as to length of time to implement, cost to the Utility, expected return on investment (ROI), frequency of suggested maintenance and/or replacement programs such as leak surveys, and meter testing/repair/replacements. Major CIP programs may be identified as well such as main replacements, implementation of an AMR system, or any other long term program that may be considered.

### Reports

At the conclusion of the water audit a final report will be prepared detailing the step by step process involved with each segment of the audit. In addition, there will be a written discussion of the results with the proposed remediation steps suggested. There will be a printed copy of the Audit Spreadsheet along with the Water Balance detailing the breakdown of each analyzed component. For each segment of the audit where a validity score was input, there will be a short discussion of each individual score. This will be useful in terms of short- and long-term planning.

## AWWA Water Audit Software

M.E. Simpson Co. Inc. will provide the Water Audit in a digital format. That format will be Version 5 of the AWWA Water Audit Software.

M.E. Simpson Co. Inc. staff will provide detailed instructions on how to use this software to selected water division managers of the Village. The instruction will be provided at offices of the water managers and may need up to two sessions of instruction to makes sure the Village staff is comfortable with the use of the software.

## Audit Timeline

### ***Task 1: Determine System Input***

Week 1, 2, 3: Review Utility Water Production Records and Data stream

Week 3: Conduct analysis of Master Meter/Production Meter past accuracy tests (if available)

### ***Task 2: Determine Authorized Consumption***

Week 3: Identify and Evaluate existing data for current water loss reduction

Week 4: Data Collection from Accounting and Billing

Week 5: Calculate Consumption (Billed Metered, Unbilled Metered, Metered Unbilled, Unbilled Unmetered).

### ***Task 3: Determine Apparent Loss***

Week 4-5: Identify Apparent losses

Week 6-7: Identify Large and Small Meter potential inaccuracies

Week 7: Calculate Apparent losses.

### ***Task 4: Determine Real Losses***

Week 8: Calculate Real Losses.

Week 9: Evaluated distribution system data (miles of main, number of service connections Operating pressure)

Task 5: AWWA Water Audit Spreadsheet

Week 10: Work through spreadsheet and Water Balance

Week 11: Calculate Performance indicators for water system.

### ***Task 6: Provide Recommendations for Economically Viable Water Loss Intervention Programs***

Week 11: Develop and submit draft final report

Week 12: Prepare Audit I Report and Audit Software

## Large Water Meter Evaluation, Testing and Repair Master/Production Water Meters

### The Field Scope of Service is understood to be the following:

Our Project Team will furnish all labor, material, transportation, tools, and equipment necessary to test production meters selected by the Utility. Our Project Team shall be required to provide such skilled and trained personnel and equipment necessary to complete the work herein specified. **There will be a minimum of Two Persons per team working on the testing program at all times.**

### Venturi, Propeller and Mag style Large Water Meters

- ◆ Work in an orderly and safe manner to insure protection of the local residents, Utility employees, and the Field Staff so that no avoidable accidents occur.
- ◆ All Field Staff will have readily observable photo identification badges worn while in the field.
- ◆ Assess all meters listed in the test group. This assessment will include making observations of water usage on site as well as observed meter readings to determine if the meter is the correct type and size for the particular application.
- ◆ Meters and test tap locations will be inspected ahead of the testing to allow for the installation of proper test taps to insure the overall accuracy of the testing and provide for the best test conditions available, given the site conditions.
- ◆ Determine if meter can be tested in place, if not, make recommendations to Utility to correct setting so meter can be tested in place. This would include sketches, drawings, etc., of site and turned into the utility so improvements can be made.
- ◆ A meter log shall be maintained indicating all meters to be assessed in the current test group. This log will be reviewed when the Project Team is verifying the meter data supplied by the Utility and corrections will be made to provide updated records to the Utility. This log will be used as part of the periodic meter reports turned into the Utility.
- ◆ Schedule the meter test with the utility and wholesale water customer during normal working hours. Exceptions to testing times will be made on a case-by-case basis. After hours or weekend testing may be required for severe scheduling conflicts.
- ◆ Meters may be tested across a range of flows in order to determine patterns of wear at various flow rates but in most cases the meter will be tested at its normal usage flow rate. These flow rates used may be a combination of AWWA recommended flow rates (per M-6 manual of the AWWA) and meter manufacturer flow rates or what local conditions allow.
- ◆ Meters will be tested (by MESCO), calibrated (by Utility technicians) to bring them within accepted accuracy limits. The current accuracy limits used by M.E. Simpson Co. has been derived from the AWWA M-6 and M-33 Manuals and are set at 97% - 103% as compared to the flow measured by the Polcon Pitot Rod. A Statement of Accuracy for the equipment and the procedure used are listed at the end of this document.
- ◆ The equipment used will be that which was described in the “Equipment to be Used” section.

- ◆ The Project Team will document all meter testing results. Meters that require extensive repairs (not worth time and material) or if the meter is obsolete, will be brought to the attention of the Utility so a potential meter change-out can be analyzed by the Utility.
- ◆ The Project Team will report daily to the assigned Water Department Manager and go over the progress of the previous day, as well as cover what meters will be tested the current day.
- ◆ It may be necessary to conduct parts of the meter-testing program during “off hours” such as at night. This may be required in buildings that have a high daily usage but is closed at night. The Project Team will give 24-hour notice of intent to test meters that may require after hours or nighttime work. This is so the Water Utility can plan for the area to be accessed, give notification to the Police department, as well as other Public Works Divisions as to the activity that will take place.
- ◆ Meters located in confined spaces shall be tested using accepted confined space entry procedures.
- ◆ Any valves that fail or break during operation to isolate the water meter for testing will be repaired or replaced at the expense of the owner. M.E. Simpson Company cannot be held responsible for possible valve failures due to pre-existing conditions during the testing procedure.

## Typical Test Procedure

All master meters will be tested in accordance with American Water Works Association standards as they apply to the particular flow meters used by the utility. The master meter can be tested at a single flow or over a broad range of flows using an “in-line” pitot rod. M.E. Simpson Company manufactures and uses the Polcon<sup>®</sup> Pitot Rod along with the **Polcon<sup>®</sup> Sentry electronic flow recorder**. The Polcon<sup>®</sup> Sentry flow recorder is a totally unique solid state microprocessor type recorder that senses, gathers, stores, and processes differential pressure (your range selection of –5 to 30 inches of water column) from our pitot rod. The Sentry generates a 4-20mA signal using a Rosemount differential pressure recorder along with a Telog 3000 series data recorder. The recorder can be set to measure short tests such as a 10 minute test period as well as twenty four-hour flows from 1 day (with a sampling period of one minute) to 7 days (with a sampling period of two minutes). The data can also be exported to a spreadsheet program, such as Excel, so the data can be analyzed and reviewed with the Polcon<sup>®</sup> spreadsheet forms. With this process we eliminate manometers, rulers, **toxic** indicating liquids and manual entries. Manual entries may be performed as a backup. The Polcon<sup>®</sup> Sentry electronic recorder is used with the Polcon<sup>®</sup> Pitot Rod and produces test results in the plus or minus 2% range. The testing will be done through an existing 1” corporation stop. First the pipe will be callipered, using the Polcon Pipe Caliper, to determine the exact area of the pipe. Then the Polcon Pitot Rod will be installed and connected to a Sentry Electronic Recorder, an electronic differential pressure recorder, which is then programmed via a notebook computer.

## Venturi-Style Flow Meters

A second calibrated Sentry recorder will be installed (see diagram below) in a parallel setting to the sensing lines of the Venturi meter to monitor the performance of the Venturi differential during the test. Also a 4-20 mAmp Telog recorder will be installed after the DP cell from the Venturi to record the signal going to the SCADA system. This will help in the diagnosis of potential data stream issues.

Access to the Venturi DP cell would be needed. If the Venturi is in a vault with the DP cell, access to the vault would be needed.

Once the initial test has been conducted, results calculated, re-ranging settings determined for the meter, the meter will be adjusted by the Utility and a second short flow test will be conducted to make sure the meter is within accuracy limits of 97% to 103%.

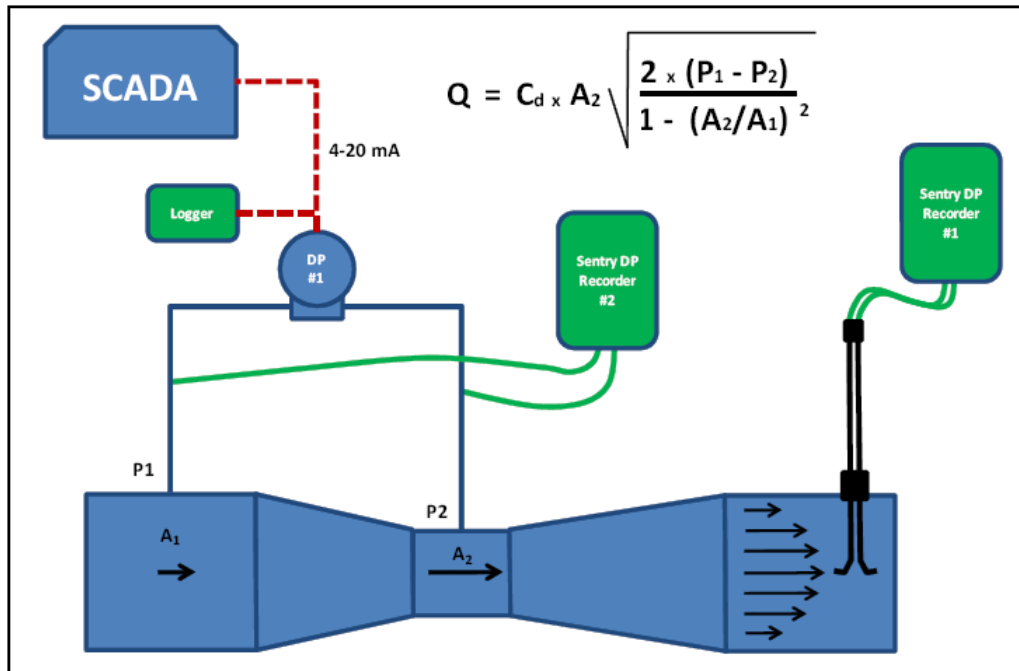
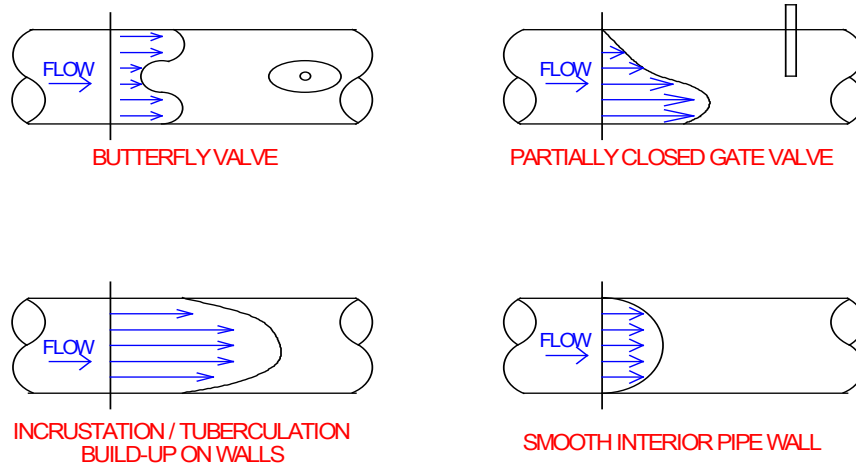

Fig. 1 – Venturi Meter Test Set Up

## Test-tap location, all meters

In order to have the best possible test results from flow testing on site, conditioned flow must be available at the site of the test tap. Therefore, it is imperative the test tap locations be given the upmost consideration. Inspections of test tap locations may need to be made and previously installed test tap location that produced marginal flow profiles may need to be moved and new taps installed. It is important to understand that in some cases compromised test locations are the best that can be had at the given site, due to the limitations of space, piping configurations, water treatment plant layout or other factors. If these conditions are encountered, the Utility will be made aware of the potential effect on the flow test (see following graphic).



**Traverse**

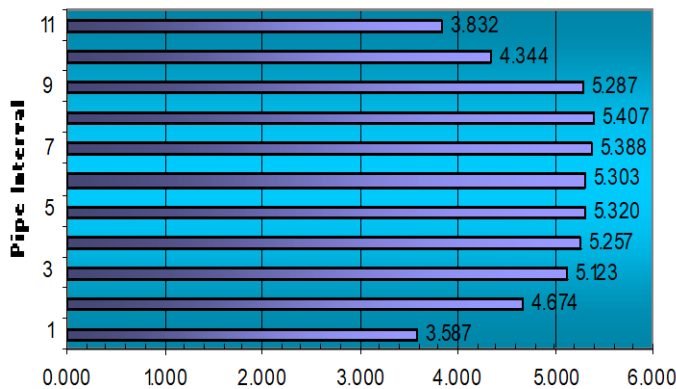

*The flow profile shown above is what is desirable for a good test.*

The Utility will assist, where necessary and for general safety, with traffic control. At each test site the Utility must provide a 1" corporation stop that is located 10 pipe diameters from any type of obstruction, valve, check valve, reducer, elbow, or tee. The corporation stop may be located either upstream or downstream of the meter. For Mag style meters it is preferred the corp stop be installed *downstream* of the meter. If the corporation stop cannot be installed inside a building due to space limitations and must be installed outside below ground then a vault, minimum 48" diameter, must be installed. The manhole opening must be directly over the corporation stop if the vault top is less than 30 inches or [the diameter of the pipe plus one-foot] from the corporation stop, whichever is greater. This is to allow for sufficient room for installation of the pitot rod. If a vault cannot be installed then the Utility must provide a trench box, shoring, or an excavation that meets OSHA trenching standards. A "surface mount" tap can also be used provided the base of the pipe is not deeper than 8'.

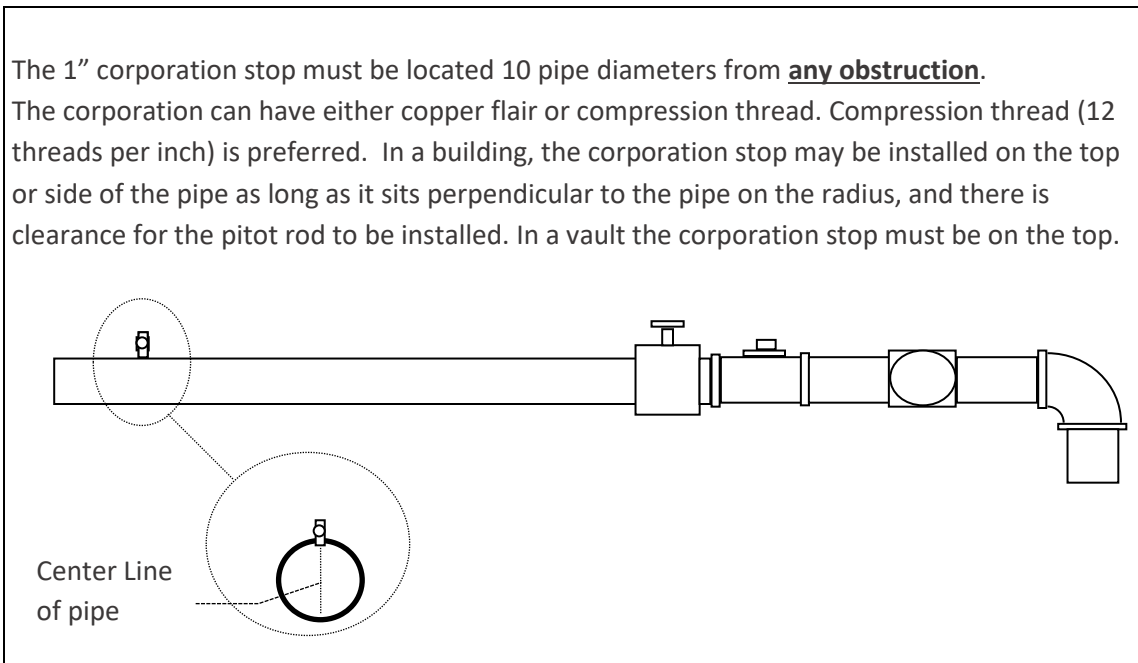

**\*\*If the corporation is not direct tapped, but is installed in a saddle, then it is very important that the pipe be drilled with a 1" drill bit. The standard 7/8" drill bit will not work. The pitot equipment will not fit through a hole of 15/16 of an inch or smaller.**

## Velocity of Flow

Another consideration for the accuracy of the flow test is the velocity of flow where the Polcon Pitot Rod is measuring flow. Since the Polcon Pitot Rod coupled with the Polcon Sentry Recorder is essentially a "portable" differential producing flow meter, there is a limitation to how low a flow that can be accurately measured without compromising the test results. M.E. Simpson Co., Inc. highly recommends that the flow at the test site be at least 2 feet per second (one inch of water column) to insure flow test results are not compromised. If the measured flow velocity falls below 2fps, the lower the flow rate goes, the higher percentage of error gets introduced into the test results. This issue can be further complicated by low static head that is common on gravity feed lines where flow meters have been installed. However, if flow can be held at or above 2 fps during the test, and possibly a range of flows recorded, a flow curve can be generated for the meter. If the velocity of flow at a test site is below the recommended 2 fps, the Utility will be made aware of the potential for this error. The test may need to be delayed until higher flow can be achieved.

## Venturi Meter Exceptions

In certain cases where pipe material limitations came into play such as concrete pressure pipe upstream and downstream of a Venturi meter, and piping configurations, a Pitot corp stop has been installed on the diverging cone of the Venturi meter, downstream of the throat of the Venturi. While this seems to be out of order with trying to get conditioned flow at the test site, the flow profile at this location indicated that it was acceptable as a test site location. This is something that would only be recommended as a last resort, but flow test results including flow profiles indicated this was a good location to conduct the flow test.

## Mag Style Meter Exceptions

Test corp locations for Mag style meters are very important. The test corp location must not be immediately upstream of the Mag meter because the flow at the Pitot rod will cause flow disturbances inside the Mag meter causing it to measure flow incorrectly. It is recommended that the test corp be at place downstream of the Mag meter or if placed upstream, there needs to be at least 10 pipe diameters of space between the Pitot test corp and the Mag meter.

## Quality Control for Flow Meter Testing and Calibration

The level of quality control for large flow meter testing is a matter of taking in all the above considerations and applying those considerations to each individual meter setting as it is being evaluated. As stated earlier, AWWA meter testing specifications have been stated for testing under “controlled” conditions in a meter testing shop. In the field, piping conditions and configurations are not conducive to conditioned flow sometimes making meter testing challenging if not sometimes impossible. It is the level of experience of the meter testing technicians to be able to differentiate and make the call as to when conditions are such where accurate meter tests can be conducted to allow for a reliable test. In addition, M.E. Simpson Co., Inc. has on staff engineers available that can review the data quickly and decide if the data generated is valid or if another approach is needed. When a strict methodology and field procedure is followed, the field conditions can be controlled and mitigated to produce test results that are reliable and accurate.

## Final Reports, Documentations & Communications

***M.E. Simpson Co, Inc. will perform the following:***

- ◆ Project Team will **meet daily** with assigned Utility personnel to go over areas of testing for prior workday and plan current day and tests to be conducted.
- ◆ The field technicians will be readily available by cellular phone. This will facilitate communications between the Utility and the field technicians. A **24-hour toll-free 800 number** is available for direct contact with the Project Team for emergencies.
- ◆ **Document all meter testing**, date of testing, and all data required by the utility to analyze the meter inaccuracies. These will be reported daily to appointed Utility Personnel.
- ◆ **The Project Manager will meet** with the Utility as needed for a progress report if so requested.

- ◆ **Maintain a progression list** of the project indicating meters tested and to be tested, contact names, phone numbers, etc.
- ◆ **Prepare reports** at the completion of the project which will include all meter testing reports, pump curve data and reports, listing of data readings, and possible mechanical deficiencies that need the attention of the Utility. Recommendations for system maintenance will be a part of this report based on field observations made during the testing program. **This final report shall be made available for submission to the Utility within twenty (20) working days of the completion of the fieldwork.**

### Assumptions & Services Provided by Water Utility

- ◆ The *Utility* will furnish all maps, atlases, drawings (two copies) and records necessary to properly conduct the testing program.
- ◆ The *Utility* will provide if needed, meter records such as consumption history, or any additional information that would make testing at a location easier to perform. This information shall be regarded as CONFIDENTIAL by the Project Team, and will not be shared with anyone outside of the *Utility* without consent of the *Utility*.
- ◆ The *Utility* will assist as necessary for the testing program.
- ◆ The *Utility* will also make available, on a reasonable but periodic basis, certain personnel with a working knowledge of the water system who may be helpful and for general information about the water system. This person will not need to assist the Project Team on a full time basis, but only on an “as needed” basis.
- ◆ The *Utility* will assist, if needed, to help gain entry into sites that may be difficult to get into due to security issues or other concerns.
- ◆ The *Utility* will assist with providing SCADA readings in Excel for the meters during the test periods. In addition, once new ranging limits have been calculated, the *Utility* will make those adjustments so M.E. Simpson Co. staff can re-test to verify the meter is within accuracy limits.

### Equipment to be Used

The following equipment will be used for meter testing work during the project. All material listed will be on the job site at all times.

1. All tools needed to perform testing “on site” (hand tools, pipe wrenches, etc.)
2. Confined Space Entry tripod, winch, fall protection and Gas detector

## Polcon® Equipment

The **Polcon® Sentry Recorder** is a totally unique solid state microprocessor type recorder that senses gathers, stores, and processes differential pressure from a pitot rod or other flow device. The Sentry generates a 4-20mA signal using a Rosemount differential pressure recorder along with a Telog 3000 series recorder. The recorder can be set to measure flows from 1 hour and 55 minutes (with a sampling period of 5 seconds) to 7 days (with a sampling period of two minutes) on a single set of batteries. The Sentry is self-contained, has its own power pack, weighs less than 30 lbs., and fits into the standard 20.25" manhole entrance. Data is "downloaded" using a laptop computer for further analysis. All differential pressure flow data can be permanently stored on a computer hard drive or floppy disk. The data can also be exported to a spreadsheet program, such as Microsoft Excel so the data can be analyzed and reviewed with the Polcon® spread sheet forms. With this process manometers and toxic indicating liquids will not be used.



The **Polcon® Pitot Rod** is constructed with high-grade brass to insure a device that is durable as well as accurate. The "O" ring packing and a locking device assures that all Polcon® Pitot Rods will provide a safe and leak proof installation. The solid orifice plate assures the upstream and downstream orifices remain in the same plane and directly opposite one another assuring an accurate measurement of the velocity in the pipe.

The **Polcon® Pipe Caliper** is constructed with high-grade brass and steel to insure a device that is durable as well as accurate. The "O" ring packing and a locking device assures that all Polcon® Pipe Calipers will provide a safe and leak proof installations. The caliper is used for the accurate determination of pipe diameter to obtain the true  $Q = AV$  relationship. The inside diameters are always taken to the 1/16-inch to maintain the true integrity of the hydraulic data. The unique design permits accurate determination of the pipe diameter even if the tap extends through the pipe wall.

The **Polcon® 4-20 mA Signal Recorder** consists of a Telog ILR-31 loop recorder and terminals for temporary connections to the data loop for the SCADA system.

## Water Distribution System Leak Survey

The Field Scope of Service for the Leak Survey is understood to be the following:

M.E. Simpson Co., Inc. will furnish all labor, material, transportation, tools, and equipment necessary to survey the water distribution system areas selected by the C. M.E. Simpson Co., Inc. shall be required to provide such skilled and trained personnel and equipment necessary to complete the work herein specified. **There will be a minimum of Two Persons per team working on the survey at all times.**



Leak Detection has come a long way since the early 1900's.

- ◆ Work in an orderly and **safe** manner to insure protection of the local residents, Utility employees, and the Field Staff so that no **avoidable** accidents occur.
- ◆ All Field Staff will have readily observable identification badges worn while in the field.
- ◆ The leak detection equipment to be used will be that which was described in the “Equipment to be used” section.
- ◆ Initially listen to **all fire hydrants, all main line valves**, and when necessary, selected service connections in the entire distribution system with the **FCS S30** electronic listening device or the **Gutermann AquaScope 3** electronic listening device by making physical contact with the valve, hydrant, pipe, or B-box. (Listening points that are not accessible will be given to the Utility and when corrected they will be listened to.) This will be done on the Utility’s distribution system.
- ◆ Listening distances will not exceed 400' between points. I.E., valves, hydrants, service valves or meter settings will be used with preference of listening points in order as follows; direct contact with the pipe, main line valves, hydrant valves, hydrants, then service valves or meter settings.
- ◆ Valve vaults full of water may be pumped out to facilitate listening. Sometimes full vaults can mask leak noise.
- ◆ Large diameter pipe (18”-36”) may need to have additional listening performed by listening directly above the pipe at intervals of 6-10 feet.
- ◆ **All accessible points** along PVC water mains will be physically listened to including services, main line valves, and hydrants.

- ◆ A “suspected leak” log shall be maintained indicating all areas where suspected leak noise was heard. This log will be reviewed when the Project Team is verifying the suspected leak area for confirmation of the actual existence of a leak. This log will be a part of the periodic reports turned into the Utility regardless of an actual leak located in the area or not, with an explanation of the noise source.
- ◆ When leak noise has been detected and or suspected, the Project Team will verify the suspected area a second time to confirm the noise. At least four hours will pass between the initial listening of the area before a second listen and confirmation is attempted.
- ◆ The Project Team will line locate the water main and service lines in the immediate area so the correct pipe distances can be input into the leak correlator and also so that the Water Utility will have an idea of where the water main is located prior to excavation. Non-metallic pipe locations will be “interpolated” as best that can be identified, given the line location of metallic services, Utility knowledge of the area, or other information regarding the actual location of the main.
- ◆ The Project Team will use the following Electronic Leak Correlators (either a FCS Accu-Corr, Digi-Corr, Tri-Corr Touch; Vivax Metrotech HL6000X; Ecologics LeakFinderRT w/hydrophones leak correlator), to determine if a leak is present and use the same equipment to pinpoint the leak.
- ◆ For PVC water mains only the Ecologics LeakFinderRT w/hydrophones leak correlator, will be used for correlations because of the ability for these correlators to be able to analyze the particular sound frequencies inherent to PVC pipe.
- ◆ The leak location will be marked in the field (on the surface) using environmentally formulated Precautionary Blue paint.
- ◆ The Project Team will document all leak locations with a diagram indicating the location of the leak. Other information related to that correlation will be included as part of the field sheet such as the filters used for the correlation, line locations, distances between sensors, etc.
- ◆ The field sheets will be copied, and turned into the assigned Water Department Manager daily or an agreed time period so the leak can be dug and repaired immediately. They will be classified as to the potential severity of water loss, as well as potential danger to the general public.
- ◆ The locations of leaks requiring immediate attention (immediate threat to life, injury or traffic) will be turned in as quickly as possible to facilitate the repair process.
- ◆ **“Ground miking” will not be used as the primary determination for leak locations.** Grounding miking will be done per Utility request, or when it has been deemed to be the most efficient means to listen to the water main running under ground. Large diameter mains (18” – 36”) may need this additional evaluation. This method may be used to assist in confirmation of a leak location. However, “ground miking” is solely dependent on conditions beyond the direct observations of the leak technician such as soil conditions and composition, water table, depth of pipe bury, assumed location of the water main (such as concrete pressure pipe) and compaction of pavement material causing leak sounds to scatter and echo or simply be absorbed.

- ◆ The Project Team will report daily or per request of the Utility, to the assigned Utility Manager and go over the progress of the previous day, as well as cover what will be surveyed the current day.
- ◆ It may be necessary to conduct parts of the Leak Survey during “off hours” such as at night. This may be required in areas of high traffic volume where traffic noise may affect the ability to detect leak noise, and traffic volume may affect the ability of the Project Team to be able to safely access main line valves in the middle of the street. The Project Team will give 24-hour advanced notice of intent to survey a particular area that may require after hours surveying or nighttime surveying. This is so the Utility can plan for the area to be surveyed, give notification to the Police department, as well as other Public Works Divisions as to the activity that will take place.
- ◆ A progression map shall be maintained for each section under survey indicating leak locations on the map. This will be especially helpful in quickly determining leak locations that correspond to the field leak diagrams turned into the Utility.
- ◆ As a part of the leak program, mapping discrepancies found on the current water atlas will be noted and included as a part of the final report so the Utility can make needed corrections. This will be included as a part of the periodic reporting to the Utility, thus enabling the Utility to keep up with mapping corrections.
- ◆ Distribution assets found to be in disrepair such as issues with hydrants, valves, and service lines, will be noted and turned into the Utility.
- ◆ Leaks verified on the customer’s side of a service shut-off will not be located beyond the shut-off. If a leak appears to be on the Customers’ side, the Utility will be notified first, then the customer notified and permission granted prior to the water being shut off even for short periods of time where possible and as time allows, as well as the ability for the customer to respond.
- ◆ If the Utility requests leak locations beyond the service shut off on the customer’s side of the service line, this will result in an additional charge to the leak survey based on an hourly rate and this service must be agreed upon between the Utility and M.E. Simpson Co., Inc. prior to the start of the survey.
- ◆ Valves and hydrants will not be operated without Utility permission. Valves and hydrants that break during this type of operation are the sole responsibility of the Utility. M.E. Simpson Co., Inc. cannot be responsible for valves and hydrants that break due to pre-existing conditions.
- ◆ The Utility is encouraged to dig up and repair the leaks located as soon as possible so that the area may be re-surveyed while the Project Team is still working on the survey in that general geographical location to ensure no other leaks are present in that area.

### Quality Control and Accuracy of Leak Locations

The level of accuracy of leak detection is a matter of taking in all the above considerations and applying those considerations to each individual potential leak location as it is being evaluated. Any statement made as to the level of accuracy of leak locations must be considered based on the individual conditions of each leak.



**Leak surfacing at intersection**



**Hidden leak running into drain tile**

Locating leaks on a distribution system can be very challenging. It is not a perfect science. Pipes and fittings can leak for a variety of reasons (age, poor installation, material failures, bad soils, etc.), and the ability to locate leaks is dependent on the stated variables listed in the “Project Approach”. By employing a strict methodology in the field for conducting a leak survey, these variables can be accounted for and mitigated. The depth of experience of the Project Team is extremely important to maintaining the ability to have accurate locations of leaks. Additionally, crews work as Two-Person Teams in the field, double checking the progress of the work as the survey progresses. The systematic procedure for leak confirmation has been stated in the Scope of Field Service and is restated here.

“Suspected leak areas are always listened to a second time, preferably at a different time of day than originally listened to. The mains and services will be line located to insure correct pipe distances are used for the correlations. Correlations may need to be performed several times with several configurations to insure all the possible scenarios have been covered. Sewer manholes may need to be opened and flows observed. If there is any doubt as to the existence of a leak, the area may be checked and correlated at different times to rule out water usage or other factors. The progress of the survey will be monitored by the use of daily logs and a progression map with suspected leak noise indications marked and possible leak locations will be maintained. Field leak location forms will be turned into the Utility according to the agreed schedule. The Project Team will follow up on leak locations by monitoring the repair schedule of the Utility. That way in case a potential leak location is wrong, the Project Team can return to the site and determine why the leak location was incorrect, and correct it. This means maintaining a good level of communication between the Project Team in the field, and the Utility. **As a matter of Quality Control for leaks in the field, the two Correlators (Accu-Corr and Digi-Corr) have the distinct ability to be able to detect and pinpoint more than one leak in the same relative area, thus allowing better leak coverage and insuring that one leak is not “masking” another leak in the same area.** The use of progress reports and meetings will allow for open discussions of problems encountered so solutions can be examined.”

## Utility Observations

The M.E. Simpson Co., Inc. Project Team will welcome having staff of the Utility observe field procedures while the Leak Survey is in progress. They will be happy to explain and demonstrate the equipment and techniques that are employed by M.E. Simpson Co., Inc. for detecting and locating leaks on the Water System. This may be useful for the staff of the Utility in understanding the parameters of Leak Detection, especially during an emergency such as a main break on a critical line where a major disruption of service could occur.

## Final Reports, Documentations & Communications

### **M.E. Simpson Co, Inc. will perform the following:**

- ◆ Project Team will **meet daily** with assigned Utility personnel to go over areas of survey for prior workday and plan current day and area to survey.
- ◆ The field technicians will be readily available by cellular phone. This will facilitate communications between the Utility and the field technicians. A **24-hour toll-free 800 number** is available for direct contact with M.E. Simpson Co., Inc. for emergencies.
- ◆ **Diagram all leak locations**, date of location, and classify according to severity and an estimate of loss. These will be turned in daily to appointed Utility Personnel.
- ◆ **The Project Manager will** meet with the Utility regularly for a progress report.
- ◆ **Prepare a progress report** at monthly intervals for the Utility if requested.
- ◆ **Maintain a progression map to be included with the progress reports and final report** of the project indicating leak locations with symbols indicating type and severity corresponding to the individual leak diagrams.
- ◆ Develop a **Leak Survey log** of activity which will also have confirmed leaks listed and this list will be turned in weekly (in an Excel format). The list will also be included with the final report that will include the following:
  1. Mechanical deficiencies discovered
  2. Mapping errors on the water atlas
  3. Type of monitored appurtenances
  4. Location of same for leaks discovered
  5. Total estimated loss
- ◆ **Prepare the final report** at the completion of the project which will include all leak location reports with drawings, total of estimated water loss, total pipe distance investigated, a description of the area surveyed, and other problems found in the system during the course of the survey that need the attention of the Water Utility. The leak summary will list leak types such as main leaks, service line leaks, valve leaks, or hydrant leaks. A cost benefit analysis of the survey based on the “cost to produce” water will also be included that describes the financial impact to the Utility for water loss. Recommendations for system maintenance will be a part of this report based on field observations made during the survey. **This final report shall be made available for submission to the Utility within thirty (30) working days of the completion of the fieldwork.**

Effective communication...  
accurate documentation...  
**Ensuring the success for  
the leak survey**

## Assumptions & Services Provided by the Utility

- ◆ The Utility will furnish all maps, atlases, and records necessary to properly conduct the survey. All corrected maps are to be returned to the Utility at the completion of the project.
- ◆ The Utility will assist as necessary to clean out service valves, meter pits and valve-boxes needed for listening.
- ◆ The Utility will provide a Primary Contact Person and/or secondary contact person for the Field Staff to report to on a periodic basis. This person shall act as the official liaison for the duration of the Leak Survey. This person shall have a working knowledge of the water system and will be helpful in attempting to locate particularly hard-to-find water valves for listening and for general information about the water system. This person will not need to assist the Project Team on a full time basis, but only on an “as needed” basis.
- ◆ The Utility will assist, if needed, to help gain entry into sites that may be difficult to get into due to security issues or other concerns.
- ◆ The Utility will assist, if needed, to locate all nonmetallic pipe within the service area. This would include all Concrete Cylinder pipe and Asbestos Cement Pipe.
- ◆ We will encourage the immediate digging of major leaks (main breaks) so that if there are problems with the leak location, the problems can be corrected while the Project Team is close by and can verify the site.



Leak Located



Leak repaired.

## Area to be Surveyed

The total miles of pipe to be surveyed are approximately **138** miles for the Utility.

The leak survey work includes monitoring all accessible main line valves, all hydrants, and several selected services as needed to keep listening distances within the accepted bounds and Scope of the survey.

## Large Water Meter Evaluation, Testing and Repair Master/Production Water Meters Approach

Our Project Team's philosophy behind large production Venturi and Mag style water meter testing services as incorporated in this work plan is to provide the utility the following benefits:

- ◆ Conserve freshwater resources
- ◆ **Substantially reduce** the loss of revenue through improper/incorrect metering
- ◆ Help in monitoring potential system operation and maintenance problems
- ◆ Promote proper accounting and financial reporting (GASB 34)
- ◆ Reduce the risk of water shortage and customer hardship (drought management)
- ◆ Ensure a sound and reliable water service for customers of Water Utility

A number of items uniquely qualify our Project Team in performing this Pitot Testing program. The Project Team's extensive practical experience in Master Meter testing methodology, membership on the National AWWA Meter Standards Committee and Water Loss Committee, previous large Venturi Meter testing experience, coupled with other extensive Water Loss Assessment Program experience such as Water Audits, Leak Detection, and Large Meter Assessments, will allow for a thorough examination of each Master Meter and meter setting to help reduce the total water loss and revenue loss occurring in these meters. From start up to completion, our firm is committed to furnishing a quality service in a timely manner.

Our pitot testing programs go **beyond** stated AWWA meter testing specifications. This is due to a thorough understanding of the limitations of meter testing conducted in the field versus testing meters under a "controlled environment" in a laboratory or established meter testing shop. We recognize that field conditions are much different than a meter shop and that these conditions must be taken into consideration when testing meters in the field. Also, the AWWA M-6 and M-33 manuals have no set "standards" for **field testing**, only to try to use meter manufacturer's suggested flow rates (re: pages 72-77 of the M-6 manual). Therefore, we find it imperative to adhere to a strict method of field testing while taking into consideration the AWWA meter performance standards. This methodology is designed to allow for a systematic diagnosis of the meter's performance based on the results of the field data.

Our Project Team employs the use of a Polcon® Pitot rod to accurately measure flow in a pipe for determining the accuracy of a flow meter or obtaining a flow measurement in an unknown flow scenario. This consists of an insertion pitot tube that is placed through the cross section of the pipe in the exact center to measure the average mean flow velocity. The Polcon® Pitot rod produces a differential pressure between the averaged velocity head port and the averaged static head port. The fluid velocity is proportional to the square root of the differential pressure. This differential pressure is measured and recorded over time by the Polcon® Sentry electronic recorder. The results are then compared to the readings of the flow meter being tested for the same time period and accuracy is then calculated for the flow meter.

According to the AWWA M33 manual, “Flow Meters in Water Supply” pitot testing can produce results of + 1/2 % to 5% of full scale with a “Repeatability” of 0.5 %. Using the Polcon® Sentry recorder that registers differential pressure to one one-hundredth of an inch of water column, this accuracy can be improved to the + 1/2% to + 2% range. Repeatability remains the same due to test site conditions.

Meter testing will be performed “on site” at or near the meter setting on previously installed test corps. The primary purpose for testing large meters in place is to not have to remove a large meter from its setting, thus possibly causing many other problems, but also as a matter of practicality. Additionally, the meter setting can affect the accuracy of the meter if it is improperly configured and that would be assessed as well.

- ◆ **Meters that are found to be inaccurate from the testing will be calibrated by the Utility’s technician after new ranges have been calculated.**
- ◆ **The Project Team will work with the Utility for all test scheduling and two (2) man teams will be used to perform the work.**
- ◆ **Utility personnel may be required to assist our technicians where there are issues with gaining entry due to security or other concerns as well as providing SCADA readings in Excel for the duration of the tests. By having utility staff familiar with the particular meter setting available would be helpful in determining local conditions that may affect testing.**

The success of this program can be enhanced by reviewing all available data regarding any previous testing program. The following may need to be gathered; a listing of wholesale metered accounts and past consumption records, meter reading books, field cards, notes, Excel copies of the SCADA meter data, if available. Additionally, other records such as amounts pumped into the system may need to be reviewed. The field testing of wholesale meters along with the records reviewed, shall yield updated adjusted consumption records of the Utility’s wholesale meters as well as supplying valuable information regarding the general condition of the water meter revenue generating system.

#### **An organized field approach to this Master Meter Testing project will include the following:**

- ◆ **Introduce and maintain an interactive role** with the Utility Staff for the Testing Program. Conduct short interviews with staff about particulars of the selected meter locations such as changes in water use, age of the meters, meter reading systems, et al. This will allow for a greater understanding of how the wholesale meters are functioning, thus allowing priorities to be assigned to particular segments of the work.
- ◆ **Divide areas of the distribution system** into geographic areas where meters are located so they can be tested in an orderly fashion. This would include setting a schedule and maintaining a level of Field Staffing that will insure completion of the testing program within the schedule and budget allotted. This may require access to maps of the transmission system to be examined during the course of the planning sessions to formulate a workable plan of action.
- ◆ **Perform meter testing, working with the utility staff to adjust meters needing calibration, and possible retests to insure accuracy.** Document all meter testing in a manner that will allow a prioritized list of obsolete meters or un-testable meters to be replaced or piping corrected to allow testing at a future date.

- ◆ **Provide constant communication** with the Utility staff so problem meters and/or wholesale water customers can be addressed in a timely manner.
- ◆ **Provide instruction and council to Utility staff** during the course of the testing program so once the program is concluded, the Utility staff will have a complete understanding of all the parameters of conducting Pitot testing with the established goal of reducing the total revenue loss due to inaccurate metering in the system.
- ◆ **Provide daily communications with Utility staff** during the course of the project indicating pertinent details regarding the testing conducted each day.
- ◆ **Provide final meter reports** indicating all the pertinent details regarding the testing program.
- ◆ **Provide recommendations for future testing programs** such as a methodology and frequency for testing in the transmission system.

## Water Distribution System Leak Survey Approach

This Leak Detection program is needed to be able to help the Utility control the water losses in the distribution system. Therefore, it is imperative the selection of a qualified Project Team be conducted with the utmost care with thorough research. Any team selected should have no trouble finding large leaks. When the first large leak is located, it will be impressive and the project team will look great. However, it is especially important to be able to locate *all the leaks that can be possibly located*, including all the small leaks that possibly can be masked by the larger leaks. That will be the real true test of the mettle and ability of the leak detection crew. In addition, gathering field data for the general condition of the distribution system is something the project team will need to be well versed in. Flowmeter maintenance and flowmeter testing is also a practical way of controlling real water losses in the system. Therefore, a practical project management plan with a proven QA/QC plan is needed to insure that this happens.

M.E. Simpson Co., Inc.'s philosophy behind water distribution system leak surveys and leak detection services as incorporated in this work plan is to provide the Utility the following benefits:

- ◆ Conserve freshwater resources
- ◆ Reduce the cost of lost water through leakage
- ◆ Conserve energy and reducing treatment costs by reducing pumpage
- ◆ Help in monitoring potential system operation and maintenance problems
- ◆ Promote proper accounting and financial reporting (GASB 34)
- ◆ Reduce the risk of water shortage and customer hardship (drought management)
- ◆ Ensure a sound and reliable water service for customers of the Utility

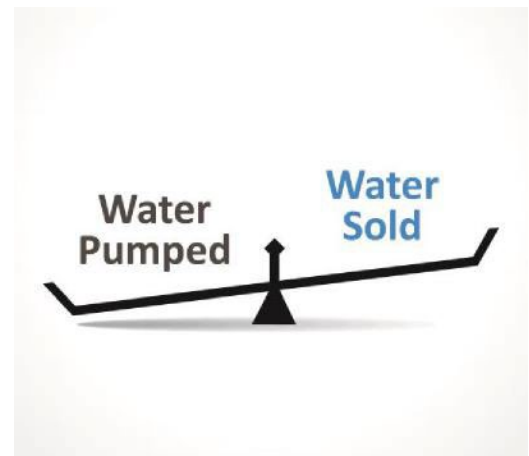

A number of items uniquely qualify M.E. Simpson Co., Inc. in performing this leak detection program. The Project Team's extensive practical experience in leak detection methodology coupled with other extensive Water Loss Assessment Program experience such as Water Audits, Meter Testing, and Master Meter Assessments, will allow for a thorough examination of the Distribution system to help reduce the total water loss occurring in the distribution system. From start up to completion, our firm is committed to furnishing a quality service in a timely manner.

## Equipment to be used

The following equipment will be used for acoustic leak detection work during the leak survey. All material listed will be on the job site at all times.

- ◆ **FCS Accu-Corr, Digi-Corr, Tri-Corr Touch Leak Correlator; Vivax-Metrotech HL6000 Leak Correlator; or Ecologics LeakFinderRT w/hydrophones Leak Correlator**
- ◆ **FCS S-30 electronically enhanced listening device or Gutermann AquaScope 3 electronically enhanced listening device.**
- ◆ **RADIO DETECTION LINE LOCATORS.**
- ◆ **SCHONSTEDT, FISHER LABS or CHICAGO TAPE magnetic locator.**



The FCS S-30 or Gutermann AquaScope 3 will be used during the initial surveying process. Both units use highly sensitive transducers to detect leak noise along the pipe or appurtenances attached to the pipe. There is an adapter plate that can be used with the transducer as a “ground microphone” so that this type of leak detection method is available for the crew to use if needed.

**The all our Correlators, amplifiers, transducers and related equipment are sent in to the manufacturer annually for software upgrades as well as system checks to insure the equipment is operating at optimum levels. Records of these system checks and calibrations are kept on file and are available upon request.**

The Radio Detection Line Locator is used to locate buried metallic water pipe. Line locating the water main and services in areas of suspected leaks is necessary so that the layout of the pipe and correct distances of the pipe can be verified. When a leak correlation is being performed on a suspected leak, the proper distance will be entered into the leak correlator. If the water lines are not properly located, it is possible that incorrect pipe distances could be entered into the correlator, thus the leak location could be inaccurate causing the digging of a dry hole. Also, when the Utility crews are ready to dig up the leak area for repair, having the proper location of the pipe is necessary.

The Magnetic locator is a required tool so that buried mainline valves and curb-stops can be located for listening and /or leak correlation if needed.

## Project Field Approach – Leak Detection

When leaks occur on a water pipe, the water escaping the pipe under pressure produces friction, and thus “leak noise.” The ability to detect, and then pinpoint leaks on water pipe is dependent on several variables. All these variables need to be analyzed by the Project Team during the course of the Leak Survey in order for successful leak locations to occur. These variables include:

- ◆ **Pipe Material.** Different pipe materials cause sound waves to travel at different velocities
- ◆ **Pipe sizes.** Different pipe sizes cause sound waves to travel at different velocities. Larger pipes will cause the sound to travel slower than on smaller pipe due to the amount of pipe material for the sound to be absorbed into
- ◆ **Water pressure on the pipe.** Lower pressure will not produce as much leak noise as higher pressure
- ◆ **Flow velocity in the pipe.** Water moving through the pipe can affect the transmission of leak noise on the pipe and the ability to detect leakage
- ◆ **Water table.** High levels of ground water can affect ability to hear leaks on the pipe. Soil conditions - types of soils can affect ability to detect leaks due to the density of the soil surrounding the pipe
- ◆ **Size of the leak in the pipe.** Larger leaks can in some circumstances produce lower noise levels than smaller leaks
- ◆ **Mechanical noise.** Pump noise from a nearby pump station can affect the ability to detect leaks as well as noise from electrical transformers

**M.E. Simpson Co., Inc.’s extensive field experience in leak detection will allow for a thorough examination of the Utility’s distribution system.**

The success of this program will be dependent upon reviewing all available data regarding the operation of the distribution system. The following will need to be gathered; all as-built drawings of the water distribution system, all original atlases, all books, field cards, notes, computer copies of the distribution system, valve cards, hydrant cards and a copy of a digital map of the Utility, if available.

Additionally, other records such as amounts pumped into the system will need to be reviewed. The field verification of leaks and associated locations, along with the records being reviewed, shall yield updated location records of the Utility’s leak locations as well as supplying valuable information regarding the general condition of the distribution system.

### **An organized field approach to this Leak Survey project will include the following:**

- ◆ **Introduce and maintain an interactive role** with the Utility Staff for the Leak Survey Program. Conduct short interviews with staff about particulars of the distribution system such as problem areas prone to leaks, age of pipe, pressure problems in the distribution system. This will allow for a greater understanding of how the distribution system is functioning allowing priorities to be assigned to particular segments of the work

- ◆ **Divide areas of the distribution system** into geographic areas that can be surveyed in progression and leak areas pinpointed in an orderly fashion. This would include setting a schedule and maintaining a level of Field Staffing that will insure completion of the Leak Survey within the schedule and budget allotted. This will require all maps of the distribution system to be examined during the course of the planning sessions to formulate a workable plan of action
- ◆ **Perform a Leak Survey on the distribution system** and document confirmed leak locations in a manner that will allow a prioritized list of leak repairs to be pursued according the described “Scope of Work”
- ◆ **Locate** all confirmed leaks in a manner that will allow their positions to be known and readily re-creatable by Utility personnel upon demand
- ◆ **Provide constant communication** with the Utility staff so located leaks can be addressed in a timely manner
- ◆ **Provide instruction and council to Utility staff** during the course of the Leak Survey so once the program is concluded, the Utility staff will have a complete understanding of all the parameters of conducting leak surveys with the established goal of reducing the total water loss in the system
- ◆ **Provide daily reporting** during the course of the project as well as a final report indicating all the pertinent details regarding the leak survey program.
- ◆ **Provide recommendations for future leak survey programs** such as a methodology and frequency for surveying the distribution system



## Potential Problems

Problems can occur at any point during the course of the leak survey. As outlined above, all variables need to be accounted for so these issues can be mitigated. This is done with having a good QA/QC program built into the project. Despite all precautions, things can and do go wrong.



When a major leak has been located, the Utility will need to excavate as soon as is prudent while the field team is performing the remainder of the leak survey. It is rare that a leak is missed and the Utility digs a dry hole. However, when this happens, M.E. Simpson Co., Inc. will assist in any way possible to determine why the pinpoint of the leak was off. It is imperative that if a leak is missed, that the Utility contact the project field team immediately so the field team can mobilize to the open excavation to be able to assess if a mistake was made because incorrect information was used in the initial evaluation such as; incorrect pipe material, incorrect distance between points used for correlation, size of pipe, pipes not line located correctly, or some other issue. The field team will retrace all steps used for the initial leak pinpoint and re-locate the leak. This may involve placing one or both of the transducer microphones directly on the pipe in the open excavation and performing a leak correlation to obtain a pinpoint. What matters is correctly locating the leak so it can be repaired and service restored. Once the leak has been located and confirmed, then a determination of how the pinpoint was miscalculated can be determined and rectified.

Other issues that can cause potential problems can be avoided by simply following the established field procedure described under the “Scope of Service” as well as the established QA/QC procedure. These procedures have established sequences, that when followed, yields accurate leak locations. Leak pinpointing becomes inaccurate when some or all of the variables cannot be accounted for or mitigated.

## Project GPS Locations Plan

### GPS Locations

M.E. Simpson Co., Inc.'s GPS Location Program will be accomplished by using a Trimble GPS GeoXH-6000 receiver. M.E. Simpson Co., Inc. will locate all water appurtenances and other structures selected by the utility for location with the Trimble GeoXH-6000 receiver. The units used are 12-channel receivers that will receive correction factors from a differential beacon, low flying satellite, or a Beacon on a Belt.

The feature and attribute data will be input on the GeoXH data collector using the TerraSync™ software. Data will be transferred into the GPS Pathfinder Office software. This software supports all aspects of GIS data collection and data maintenance, and can be exported into a variety of industry-standard GIS and database formats. The GPS position data that is collected will be “post processed” using current correction factors published and available on the Internet if correction factors for the correction beacon are not able to be obtained, or the low flying satellite is unable to provide correction factors. The information collected will be gathered and placed in an excel and/or an access database, which will be provided on a CD so that the information can be imported into your GIS Mapping system or other database formats.

**Once the selected appurtenances have been located, the M.E. Simpson Co., Inc. Project Team will perform the following:**

- ◆ **The Project Team will collect GPS Coordinates** of all selected appurtenances using the above “Scope of Work”
- ◆ The Project Team will work with the Utility to develop a “data dictionary” which will define the information to be collected for each attribute. The Data dictionary shall have the following but not limited to:
  - ◆ Date and time the information was gathered.
  - ◆ The unique identifying number for each attribute consistent and compatible with system presently employed by the Utility.
  - ◆ Location for each attribute referenced by Northing and Easting coordinates generated from the GPS location in the Utility’s local State Plane Coordinate system.
  - ◆ Type of Attribute (large water meter, leak location).
  - ◆ Offset information if the attribute needs to have the location determined by an offset coordinate due to blocked signals from the GPS satellites.
  - ◆ Any other data required to be collected as part of the attribute data set as defined by the Data Dictionary. This Data Dictionary will be assembled by the Project Team and the Utility.
- ◆ **The accuracy of each GPS** location will be sub-meter.
- ◆ **The location of “offset” GPS locations** shall be accomplished by use of a Laser Rangefinder with an accuracy of 1/10th of a foot with an automatic Electronic Compass coupled to the GPS data collector. This is so that a bearing and distance from the offset location to the

target GPS location can be recorded as part of the attribute data. This will allow coordinates to be generated in high tree canopy and urban canyons where normal coverage would not be possible.

- ◆ **GPS locations will need to have readings** from at least four satellites in position and a reading from a local GPS beacon, or five satellites for the position to be considered accurate as a differentially corrected GPS location.
- ◆ **“PDOP” readings need to be less than 5.** “PDOP” readings greater than 5 will not be considered as accurate locations.
- ◆ **A minimum of 30** readings for each position shall be taken.
- ◆ **Position of the GPS satellites shall be given primary consideration.** The position of the satellites shall be recorded as part of the data. If the satellites are low on the horizon, it is expected that the project team will wait until the position is better before attempting to gather the GPS position. Data collected with the satellites low on the horizon and/or poorly distributed shall not be considered valid.
- ◆ **The information collected** will be compiled into the **Pathfinder Office** or **TerraSync™** software database with the ability to export the information into a format acceptable to the Utility such as Microsoft Access, Microsoft Excel, .DXF file, or .SHP file for use in the Utility’s GIS system or CAD mapping program, and also included in the Polcon Pro-Valve® database.
- ◆ **All locations will be differentially corrected** for accuracy. A stationary beacon or mobile beacon can be set up to allow differential correction. All data will be “Post-Processed”, so that a comparison can be made to a Local stationary GPS receiver. The locations of the stationary GPS stations can be obtained from the Internet. The particular stationary GPS receiver shall be listed in the final report as the station used for differential correction. This will allow for a greater accuracy of the GPS locations.

## Documentation of GPS Locations

M.E. Simpson Co. Inc. will provide a location report for each appurtenance located, included in the final report and/or a database on a USB flash drive in a format agreed upon between the Utility and M.E. Simpson Co., Inc. valve locations will be compiled into a database such as Access or Excel.

- ◆ The GPS location data collected will be exported into a database for Utility use
- ◆ The GPS data collected shall include but is not limited to the following information:
- ◆ *Identifying number consistent and compatible with system presently employed by the Utility.*
- ◆ *Location referenced by coordinates using the **Illinois State Plane Coordinate System.***
- ◆ *Location by street and cross-street names.*
- ◆ *Type of structure.*
- ◆ *Date and time data was collected.*

## Project Schedule Plan

### Water Audit Timeline:

Is described in detail in the Water Audit section of this proposal

### Master/Production Meter Testing Timeline:

The field work will be conducted during the timeline outlined in the Water Audit Scope of Work. Once the City has provided the notice to proceed. M.E. Simpson Co. will inspect the Master Meters and determine their testability and then conduct the actual test of the meters.

### Water Distribution System Leak Survey Timeline:

The field work will be conducted during the timeline outlined in the Water Audit Scope of Work. Once the City has provided the notice to proceed. M.E. Simpson Co. will conduct the leak survey of the 138 miles of watermain in the distribution system. A 138-mile leak survey, the anticipated time of completion is a three-week period.

## Project Safety Plan

M.E. Simpson Co., Inc.'s Safety Programs cover all aspects of the work performed by M.E. Simpson Co., Inc. We take great pride in our safety plan/policy/program and that is evident in our EMR scores over the last five years. The safety of our employees, the utilities employees and that of the general public is our #1 priority.

Our Safety Plan/Policy/Program, with all of its parts, is 60 pages in length. In an effort to be more efficient and less wasteful we do not print copies of the safety program for RFPs. There is nothing secretive or proprietary contained within our plan/policy/program and we are happy to share its contents. If you would like a PDF copy of our plan/policy/program please contact Terrence Williams, Operations Manager, at 800.255.1521 and a copy of our program will be sent via email to you.

Below is an overview of our plan/policy/program:



**Safety** is a major part of any project. M.E. Simpson Co., Inc. always provides a safe work environment for its employees. **Our staff is trained in General Industry OSHA rules, Confined Space Entry & Self-Rescue, First Responder First Aid, CPR, and Traffic Control.**

While in the field on your project, M.E. Simpson Co., Inc. and its employees will follow all of the necessary safety procedures to protect themselves, your staff and the general public.

### **M.E. Simpson Co., Inc. uses Two-Man Teams for Safety and Quality Assurance.**

The use of a "one-person" leak detection team is dangerous and impractical where water mains run under roadways. It would be a dangerous precedent to allow a "one-person" team to access main line valves located in the roadway, attempt to listen to the valve with headphones on, and at the same time try to control traffic flow at that person's location in the street.

Therefore M.E. Simpson Co., Inc. adheres to the following:

- ◆ The Project Manager and the Field Manager will be trained in accordance with OSHA Standard 1910 (General Industry) and be in possession of an OSHA 10 Hour or 30 Hour Card.
- ◆ Any listening points located in a "confined space" such as pit and vault installations that **require entry** will be treated in accordance with the safety rules regarding **Confined Space Entry, designated by the Utility, The Department of Labor and OSHA.**
  - All personnel are **trained and certified** in Confined Space Entry & Self-Rescue.
- ◆ We will follow all safety rules regarding **First Responder First Aid & CPR, designated by the Utility, The Department of Labor and OSHA.**
  - All personnel are **trained and certified** in First Responder First Aid & CPR.
- ◆ We will follow all **traffic safety rules, designated by the Utility, The Department of Labor, OSHA, and the Illinois Department of Transportation (per MUTCD).**
  - All personnel are **trained and certified**, by the **AMERICAN TRAFFIC SAFETY SERVICES ASSOCIATION (ATSSA)** in Traffic Control and Safety.



**ATSSA Certified  
Traffic Control Personnel**

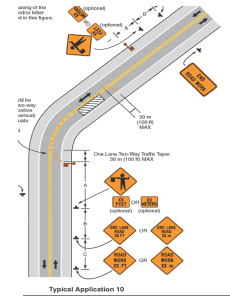

**Work Zone Safety Plans  
will be used**

Current documentations of safety training and certifications can be provided for all project personnel for the Utility. These certifications are current and up to date (for 2026) for all project personnel.

## MUNICIPAL CLIENT REFERENCES

Although it's easy for us to say what an exceptional firm M.E. Simpson Co., Inc. is to work with, we think our clients communicate it best. Since 1979, we've provided innovative water solutions for numerous cities across the U.S., including those in Arizona, California, Georgia, Illinois, Indiana, Maryland, Michigan, Minnesota, New Jersey, Ohio, Wisconsin, as well as other regions.

### **Golden State Water Corporation (2018-2019)**

#### **Creation of a Company-wide Water Loss Control Plan**

M.E. Simpson Co., Inc. created a team of water loss experts from Arcadis, Metering Technology Consultants (MTC), and M.E. Simpson Co., Inc. to perform several tasks that resulted in a companywide Water Loss Control Policies and Procedures that could be implemented to 38 water systems throughout the services areas of GSWC in California. Past company water loss practices, existing state rules, past water audits and validations, were all reviewed so that benchmark goals and a new water loss control plan could be created for the Utility. In addition, a decision tree matrix was designed to help system specific improvements to be identified and implemented for each system. A final document was created that resulted in a Water Loss Control Policy and Procedure manual for the utility. As part of the work, the project team validated two years (2017, 2018) of water audits for the 17 larger water systems, as well as conduct analysis of each of the 17 larger systems' Water Supply production metering systems. This was one to ensure the overall accuracy of the water supply data inputs into each of the water audits. The team also made several recommendations for the implementation of specific water loss control efforts for each system.

Joseph Zhao, PhD.  
Project Manager  
Golden State Water Company  
310.767.8200 ex 501

### **Village of Arlington Heights, Illinois (for yr. 2026)**

M.E. Simpson Co., Inc. performed a **"top down" water audit and Water Loss Control Plan** for the Village of Arlington Heights, Illinois. The process required review of all the past year of total water production, a review of the past year of metered consumption records, water costs, and leak issues. Patterns and trends were developed for water use using the above information and pumpage totals were compared to consumption totals to establish a baseline of potential water losses. Once this was set, Version 5 of the AWWA Water Audit Software was utilized to determine where Apparent and Real losses were occurring in the distribution system. Once the losses were divided out, costs were assigned to each component to help determine areas of potential revenue recover and to establish short range and long range plans for water loss controls. All the data was subject to cross checks using the Data Validity Scoring contained within the AWWA Water Audit Software.

Jeff Musinski  
Utility Superintendent  
Village of Arlington Heights  
[\(847\) 368-5800](tel:8473685800)  
[jmusinski@vah.com](mailto:jmusinski@vah.com)

**Department of Water Management (DWM), Chicago, IL (2012-present)**

M.E. Simpson Co., Inc. is currently performing large meter evaluations and testing for 2000 commercial/industrial accounts and 200 wholesale metering locations for the City of Chicago’s Department of Water Management (DWM). M.E. Simpson Co., Inc. is providing the field services expertise, field supervision, testing equipment, vehicles and the field personnel for this comprehensive meter evaluation and accuracy testing project. This project was developed to assist the DWM in controlling the apparent water losses in the large commercial, industrial meters and wholesale metered accounts. Over 2000 – 3” and larger meters are being inventoried, classified, and tested for accuracy. All meter locations are having digital photos taken of each meter setting along with drawings depicting piping configurations that might have an effect on meter accuracy. A large meter database is being custom created to be used with the DWM’s GIS system. The field work was started in January 2013. After the field work is completed, a complete evaluation of all the meters inspected and tested will be performed and subjected to statistical analysis for creating a complete on-going meter evaluation and maintenance program for use by DWM field staff. The large meter population will be set up so regular meter testing intervals can be based on meter revenue as well as meter size and type. This program is part of the larger effort to properly meter all water consumed in the City.

Contact:	<p><b>Mr. Matthew Quinn, Assistant Commissioner</b>                  Department of Water Management                  1424 W. Pershing Road; Chicago, IL 60609-2406                  (312) 745-8715; Matthew.Quinn@cityofchicago.org</p>

**Village of Downers Grove, IL (2005-present)**

M.E. Simpson Co., Inc. performed a Large Meter Testing Program for the Village of Downers Grove, Illinois. A number of large meters are tested and evaluated for sizing, application and accuracy. All field data is gathered and entered into a meter database and a report written documenting the accuracy of each meter prior to repair. The meters are categorized by type and size. An individual report of each meter test was made with the test results and repair comments. This was done so that the Utility staff could easily use the information to observe the recovery of lost revenue from the meter. This project is part of an ongoing effort to reduce revenue loss in the water system.

Contact:	<b>Mr. David Moody, Director of Public Works</b> Village of Downers Grove 5101 Walnut Avenue; Downers Grove, IL 60515-4074 630.434.5460; dmoody@downers.us

**Village of Westmont, IL (1986-present)**

M.E. Simpson Co., Inc. performs a Large Meter Testing Program each year for the Village of Westmont, Illinois. A number of large meters are tested and evaluated for sizing, application and accuracy. All field data is gathered and entered into a meter database and a report written documenting the accuracy of each meter prior to repair. The meters are categorized by type and size. An individual report of each meter test was made with the test results and repair comments. This was done so that the Utility staff could easily use the information to observe the recovery of lost revenue from the meter. This project is part of an ongoing effort to reduce revenue loss in the water system.

Contact:	<b>Mr. Brian Beusse, Water Division Supervisor</b> Village of Westmont 39 E. Burlington; Village of Westmont, IL 60559-1790 630.829.4453; bbeusse@westmont.il.gov

**City of Mishawaka, IN (1986-present)**

M.E. Simpson Co., Inc. performs a Large Meter Testing Program each year for the City of Mishawaka, Indiana. A number of large meters are tested and evaluated for sizing, application and accuracy. All field data is gathered and entered into a meter database and a report written documenting the accuracy of each meter prior to repair. The meters are categorized by type and size. An individual report of each meter test was made with the test results and repair comments. This was done so that the Utility staff could easily use the information to observe the recovery of lost revenue from the meter. This project is part of an ongoing annual effort to reduce revenue loss in the water system.

Contact:	<b>Mr. Brian Galletti Water Meter Div. Supervisor</b> Mishawaka Water Works 126 North Church Street; P.O. Box 363 Mishawaka, IN 46546-0363 574.258.1652; bgalletti@mishawaka.in.gov

**Macon Water Authority, Macon, GA (2012-present)**

M.E. Simpson Co. Inc. is currently performing large meter evaluations and testing for the Macon Water Authority. The company is providing the field services expertise, field supervision, testing equipment, vehicles and the field personnel for this comprehensive meter evaluation and accuracy testing project. This project was developed to assist the Authority in controlling the apparent water losses in the large commercial and industrial meters. Over 200 – 3” and larger meters are being inventoried, classified, and tested for accuracy. A large meter database has been created to be used with the Customer Service data system. After the each phase of the field work is completed, an evaluation of all the meters inspected and tested is performed for maintaining a complete on-going meter evaluation and maintenance program for use by MWA’s staff. The large meter population has been set up so regular meter testing intervals can be based on meter revenue as well as meter size and type. Also, as part of the program, M.E. Simpson Co. conducted large meter classes for the field staff of the utility so that the utility would have a better understanding of the methods used in the field to test and evaluate large meters. This program is part of the larger effort to reduce and monitor overall water losses.

Contact:	<b>Mr. Kirk Nylund; Customer Service Director</b> Macon Water Authority 790 Second Street Macon, GA 31201 478.464.5619; knylund@maconwater.org

## TOTAL PROJECT COST

A commitment to improving and maximizing the Village of Romeoville's water distribution and collection system for future generations.

M.E. Simpson Co., Inc. is pleased to offer our fee proposal for the Village of Romeoville's Water Loss Control Program. As requested, we have included our Total Project Cost with Schedule of Prices on the following page.

ITEM NO.	ITEM DESCRIPTION	QTY	UNIT	UNIT PRICE	COST
1	<b>WATER AUDIT, PROJECT PLAN AND FINAL REPORT</b>	1		N/A	<b>\$5,000.00</b>
2	<b>PITOT TEST (MASTER / PRODUCTION METERS)</b>	8	Per	\$950.00	<b>\$7,600.00</b>
3	<b>WATER DISTRIBUTION SYSTEM LEAK SURVEY (Summer 2026)</b>	280	per	\$280.00	<b>\$78,400.00</b>
4	<b>WATER DISTRIBUTION SYSTEM LEAK SURVEY (Spring 2027)</b>	280	Per	\$280.00	<b>\$78,400.00</b>
5	<b>GPSING (ADDITONAL OPTION)</b>		Per	\$10.00	
				<b>TOTAL COST</b>	<b>\$169,400.00</b>

**Randy Lusk**  
Vice President

3406 Enterprise Avenue  
Valparaiso, IN 46383

800.255.1521 P  
888.531.2444 F

randy.lusk@mesimpson.com